

Erdung nach örtlichen Vorschriften
 Mise à la terre conformément au réseau local
 Messa a terra in conformità alla rete locale
 Aarding in overeenstemming met het plaatselijk net
 Earthing in accordance with local regulation

Einspeisung
 Alimentation électrique
 Alimentazione elettrica
 Elektrische voeding
 Power supply

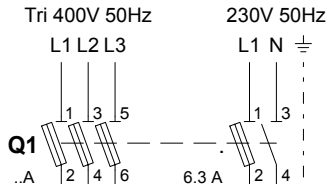

Kessel / Chaudière / Caldaia / Ketel / Boiler

F1
 Sicherheitsbegrenzer
 Th./pr. de sécurité
 Termostato di sicurezza
 Beveiliging thermostaat
 Safety limiter

S6
 Begrenzer
 Limiteur
 Limitatore
 Begrenzingsthermostaat
 Limiter

Optionen / Options / Opzioni / Opties / Options

H6
 Störung
 Panne / Défaut
 Inconveniente
 Storing
 Trouble

P6
 Betriebsstundenzähler
 Compteur horaire
 Contaore
 Uurteller
 Running hours meter

S7
 2 Stufig
 2 allures
 2 stadi
 2 trap
 2 stages

Prinzipdarstellung
 Schéma de principe
 Schema generale
 Principeschema
 Basic circuit diagram

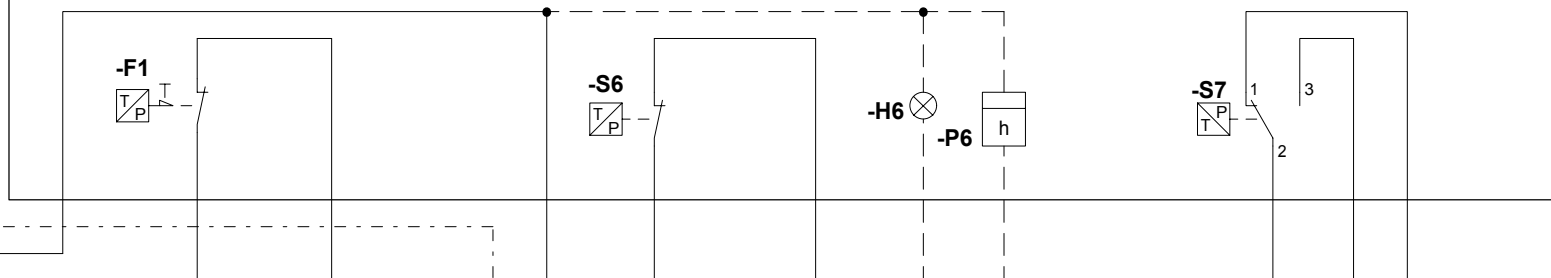

Brenner
 Brûleur
 Bruciatore
 Brander
 Burner

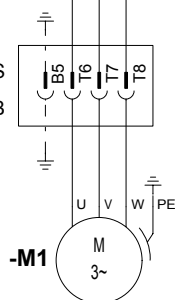
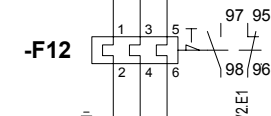
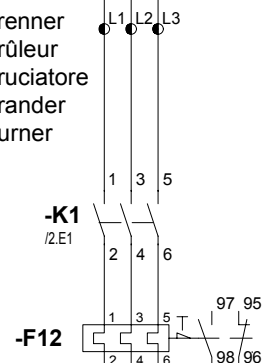

Der Schutz der Anlage muss den geltenden Normen entsprechen.
 La protection de l'installation doit être conforme aux normes en vigueur.
 La protezione dell'installazione deve essere in conformità alle norme in vigore.
 Bescherming van de installatie moet in overeenstemming volgens de wettelijk geldende normen.
 Protection of the installation must comply with the actual norms.

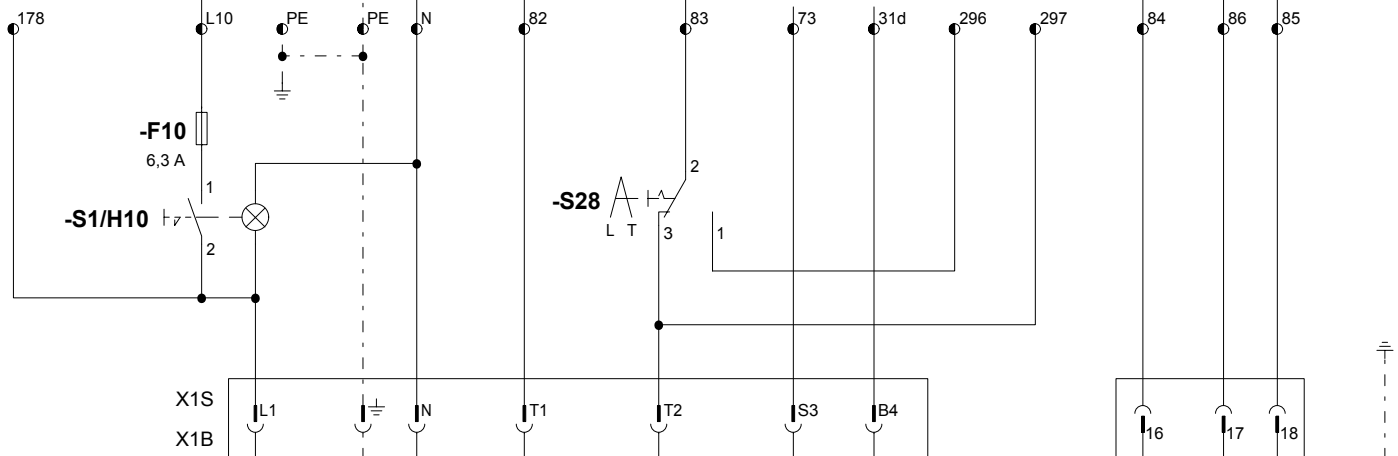

A1 **TCH 2xx**

T6/7/8

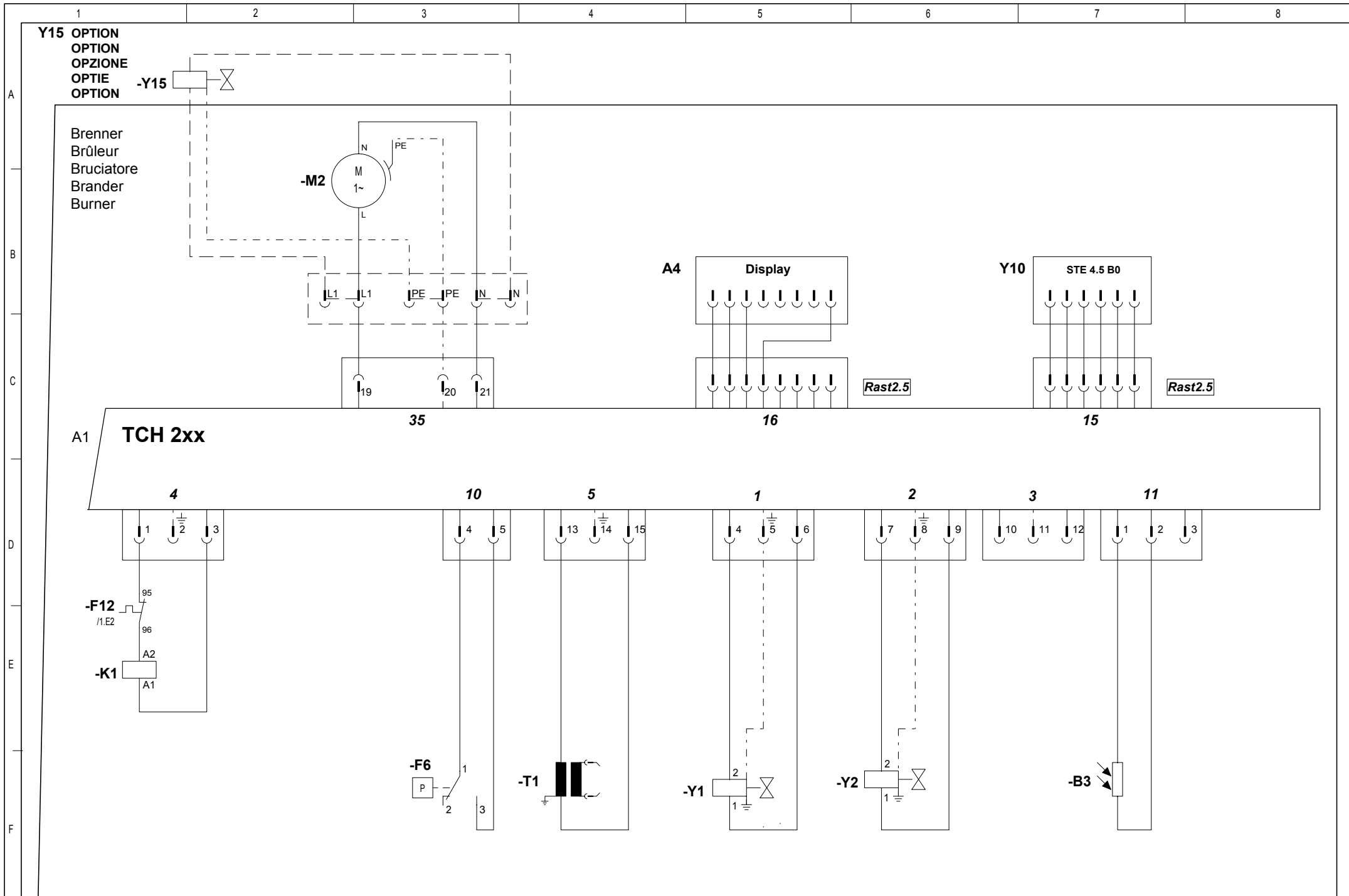

A

"DE"**"FR"****"IT"****"NL"****"EN"**

B

C

D

E

F

A1	Feuerungsautomat	Coffret de contrôle	Programmatore di comando	Bedienings en veiligheidskoffer	Control and safety unit
A4	Display	Afficheur	Visualizzatore	Uitlezing	Display
B3	Flammenwächter	Cellule	Rivelatore di fiamma	Fotocel	Cell
F6	Luftdruckwächter	Manostat d'air	Pressostato aria	Luchtpressostaat	Air pressure switch
F10	Sicherung	Fusible	Fusibile	Zekering	Control fuse
F12	Wärmeschutz M1	Protection thermique M1	Protezione termica M1	Thermische bescherming M1	Thermal protection M1
K1	Kontaktschalter des Ventilators	Contacteur du ventilateur	Contattore del ventilatore	Contacteur van ventilator	Fan unit contactor
M1	Brennermotor	Moteur du brûleur	Motore del bruciatore	Brandermotor	Burner motor
M2	Pumpenmotor	Moteur de la pompe	Motore della pompa	Pompmotor	Pump motor
S1/H10	Ein/Aus	Marche/arrêt	Acceso/spento	Aan/Uit	ON/OFF
S28	Inter-Fernsteuerung / Vor Ort	Inter. Télécommande/local	Interr. Telecomando/locale	Schakelaar Afstandsbediening/lokaal	Local/remote control inter.
T1	Zündtrafo	Transformateur d'allumage	Trasformatore d'accensione	Ontstekingstransformator	Ignition transformer
Y1	Oelventil Stufe 1	Vanne fuel 1° allure	Valvola gasolio stadio 1	Olieventiel trap 1	Oil valve stage 1
Y2	Oelventil Stufe 2	Vanne fuel 2° allure	Valvola gasolio stadio 2	Olieventiel trap 2	Oil valve stage 2
Y10	Luftklappen-Stellantrieb	Servomoteur air	Servomotore aria	Servomotor lucht	Air damper motor
Y15	Schutzventil (OPTION)	Vanne de protection (OPTION)	Valvola di protezione (OPZIONE)	Beschermingsventiel (OPTIE)	Protective valve (OPTION)
296/297	Ein/Aus ferngesteuert	Marche/arrêt par télécommande	Acceso/spento con telecomando	Aan/Uit met afstandsbesturing	ON/OFF by remote control

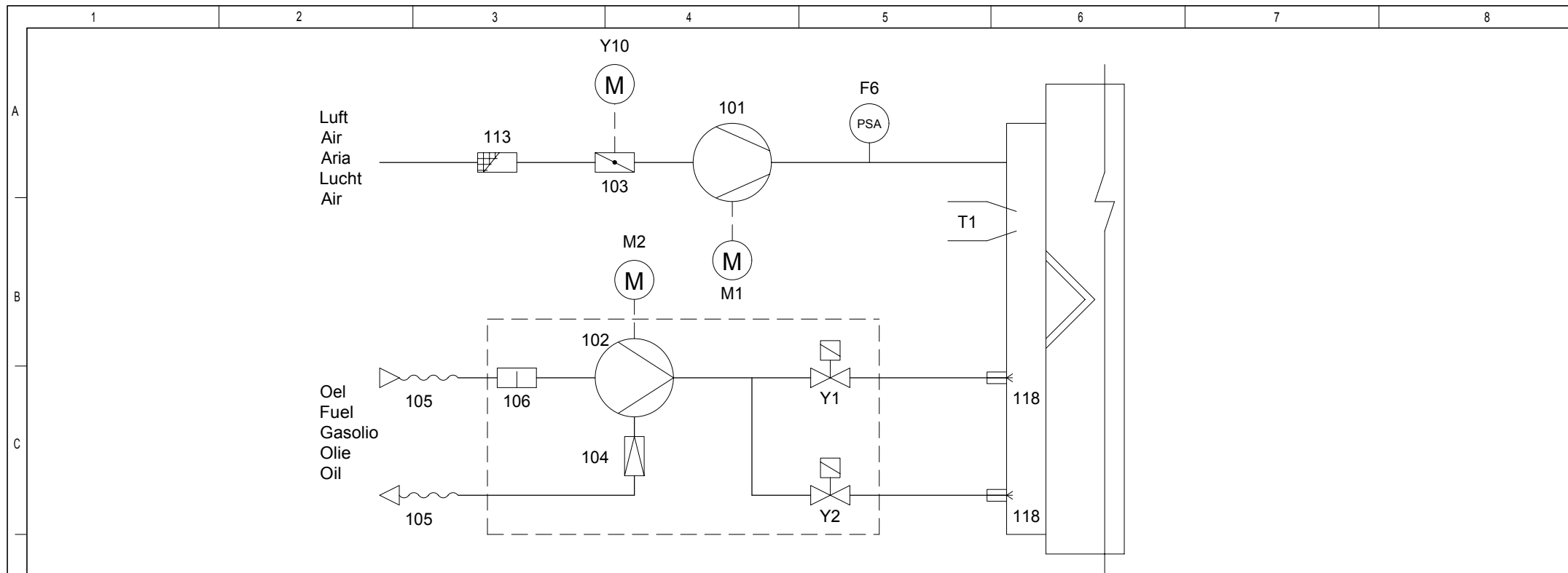

F6	Luftdruckwächter	Manostat d'air	Pressostato aria	Luchtpressostaat	Air pressure switch
M1	Brennermotor	Moteur du brûleur	Motore del bruciatore	Brandermotor	Burner motor
M2	Pumpenmotor	Moteur de la pompe	Motore della pompa	Pompmotor	Pump motor
T1	Zündtrafo	Transformateur d'allumage	Trasformatore d'accensione	Ontstekingstransformator	Ignition transformer
Y1	Oelventil Stufe 1	Vanne fuel 1° allure	Valvola gasolio stadio 1	Olieventiel trap 1	Oil valve stage 1
Y2	Oelventil Stufe 2	Vanne fuel 2° allure	Valvola gasolio stadio 2	Olieventiel trap 2	Oil valve stage 2
Y10	Stellantrieb	Servomoteur	Servomotore	Servomotor	Servomotor
101	Ventilator	Ventilateur	Ventilatore	Ventilator	Blower
102	Pumpe	Pompe	Pompa	Pomp	Pump
103	Luftklappe	Volet d'air	Serranda aria	Luchtklep	Air flap
104	Druckregler	Régulateur de pression	Regolatore della pressione	Drukregelaar	Pressure regulator
105	Schlauch	Flexible	Tubi flessibili	Soepele leiding	Hose
106	Filter	Filtre	Filtro	Filter	Filter
113	Ansauggitter	Grille d'aspiration	Scatola dell'aria	Luchthuis	Air box protection
118	Düse	Gicleur	Ugello	Sproier	Nozzle